

**SERIES  
51mm (2") PRESSURE PLATE  
FRAMING SYSTEM****I. GENERAL****Scope of Work**

Furnish materials, labour, plant, equipment, related items and services necessary for the supply, complete fabrication and installation of glazed curtain wall aluminum framing as shown on the drawings, required by job conditions and specified herein.

(Note: Structural Glazing:

Important items to be included wherever possible

1. Sealants, compatibility of materials and other related.
2. UV radiation v/s glass unit sealants - double seal design, sealants used and compatibility of materials.)

**Work Not Included**

Structural support for the system, steel and other embeds in concrete or masonry, interior moulding, closure or trim as well as roof membrane and flashing unless specifically detailed and called out as such.  
(Specifier List of Other Exclusions)

**Related Work Specified Elsewhere** (Specifier List)**Submittals****Shop Drawings**

Prior to fabrication submit shop drawings showing frame elevations, full size details as far as practical, all dimensions, coordination with related work, provision for thermal expansion and main structure deformations and tolerances, sealing and caulking joints and their sizes, material and installation notes as well as all necessary references to local Building Code requirements.

**Samples**

Before any work is fabricated, all requested representative and properly labeled samples, including specified products with their finishes, shall be submitted to the Architect for his approval.

**II. PRODUCTS****Glazing System**

- ° The system must allow for full integration with the building envelope, utilize the Rain Screen Principle Design.
  - ° A properly designed vent system, with respect to the weep hole such as size, shape, number and locations, must allow for full pressure equalization and compartmentization of the wall.
  - ° Aluminum framing shall be **5000 Series**, thermally insulated, as manufactured by **Aluminex**.
  - ° The system shall be outside-glazed, able to accommodate 25.4mm/ 1" sealed units, 6.4mm/ ¼" single glass - at vision, and/ or single spandrel glass and framed metal back-pan utilizing extruded aluminum adaptor, or frameless metal back-pan (Specifier selection), with required thermal insulation, as specified and shown on the architectural drawings.
  - ° The aluminum profile's standard dimensions shall be: 50.8mm/ 2" wide and as deep as required by load and span conditions.
- If required, steel reinforcing shall contribute to the aluminum framing structural capacity.
- ° Glass retention shall be exterior pressure plate throughout, dry-dry glazing.
  - ° Whenever substitute systems and/or products are considered, supporting data must be submitted ten (10) days prior to bid date to allow for valid comparison.

**Performance**

- ° The minimum requirements shall be based on the following ASTM test standards: E-283 Air Infiltration, E-331 Water Penetration, and E-330 Structural Performance with L/200 or 19mm / 0.75" (whichever is less) deflection limitations.
- ° Expected deformation and (seismic) movement allowances shall be referred to the structural design of the building.

**Materials**

- ° Extruded aluminum shall be AA 6063 T6, Fy = 170 MPa / 25 KSI, alloy and temper minimum, or other as required by the Code and Standards, able to meet or exceed structural and finishing criteria as specified.
- ° Any defects impairing strength, durability or appearance are not acceptable.
- ° Sufficient strength and size bolts and fasteners shall be made of corrosion-resistant and compatible material such as cadmium or zinc plated carbon steel type 302 or 304, or aluminum.
- ° Anchoring brackets, structurally adequate, shall be extruded aluminum, or formed aluminum or steel, all painted to match the framing.
- ° Anchoring fastener or bolt locations and minimum penetration requirements shall follow manufacturer's specifications.
- ° Dissimilar materials shall be separated with approved bituminous paint or spacers, to prevent any galvanic action (corrosion).
- ° Glazing gaskets shall be dense extruded elastomeric rubber such as Neoprene, EPDM, Silicone or other compatible materials.
- ° Glazing profiles shall be designed and sized to work with the system and properly serve glazing rabbet assembly providing uniform pressure in the range of 1.05 to 1.70 kN/m / 6 to 10 lb/in.
- ° Setting blocks must be properly sized (L mm = 25 mm/ 1" per each 1 m<sup>2</sup>/ 10 sqft of glass, but not less than 100 mm/ 4"), placed at 1/4 points, and compatible with the insulating glass sealant.

**Finish**

- All exposed surfaces shall be free from defects, scratches and serious blemishes. Aluminum shall receive one of the following available finishes specified by the Architect:
- i) Standard commercial clear anodic coating integral colour (02),
  - ii) Standard commercial bronze hardcolour anodic coating (04),
  - iii) Optional anodic coating finishes are light bronze or black,
  - iv) Other paint qualities and colours in baked enamel - Specifier selection

**III. EXECUTION****Fabrication**

- ° Fabricate and assemble in strict accordance with the approved shop drawings and manufacturer's published recommendations.
- ° The System shall allow for conventional glazing on four sides with projecting pressure plates and snap-on cap where required with glass hard bite not less than 12.7mm/ 0.5".
- ° Aluminum mullions shall be connected accurately to each other by standard spigot or screw spline method, properly sealed at all "air seal line" joints to assure air and water tight installation.
- ° Resilient glass setting must be achieved by use of applicable gaskets and/ or spacers.

**Installation**

- ° Framing shall be installed, secured and glazed by an experienced crew.
- ° Set framing level, plumb, square and aligned with other work, in accordance with approved shop drawings and manufacturer's installation instructions and published glazing standards.
- ° All perimeter joints shall be sealed and caulked with approved sealant materials to ensure a weather-tight installation and full connection with the building air and vapor barrier..

**Protection and Cleaning**

- ° All work shall be protected against damage during and after installation.
- ° After installation all exposed surfaces shall be cleaned of all contaminants.
- ° The General Contractor is responsible for protection and final cleaning.

**5000** SERIES  
51mm (2") PRESSURE PLATE  
FRAMING SYSTEM

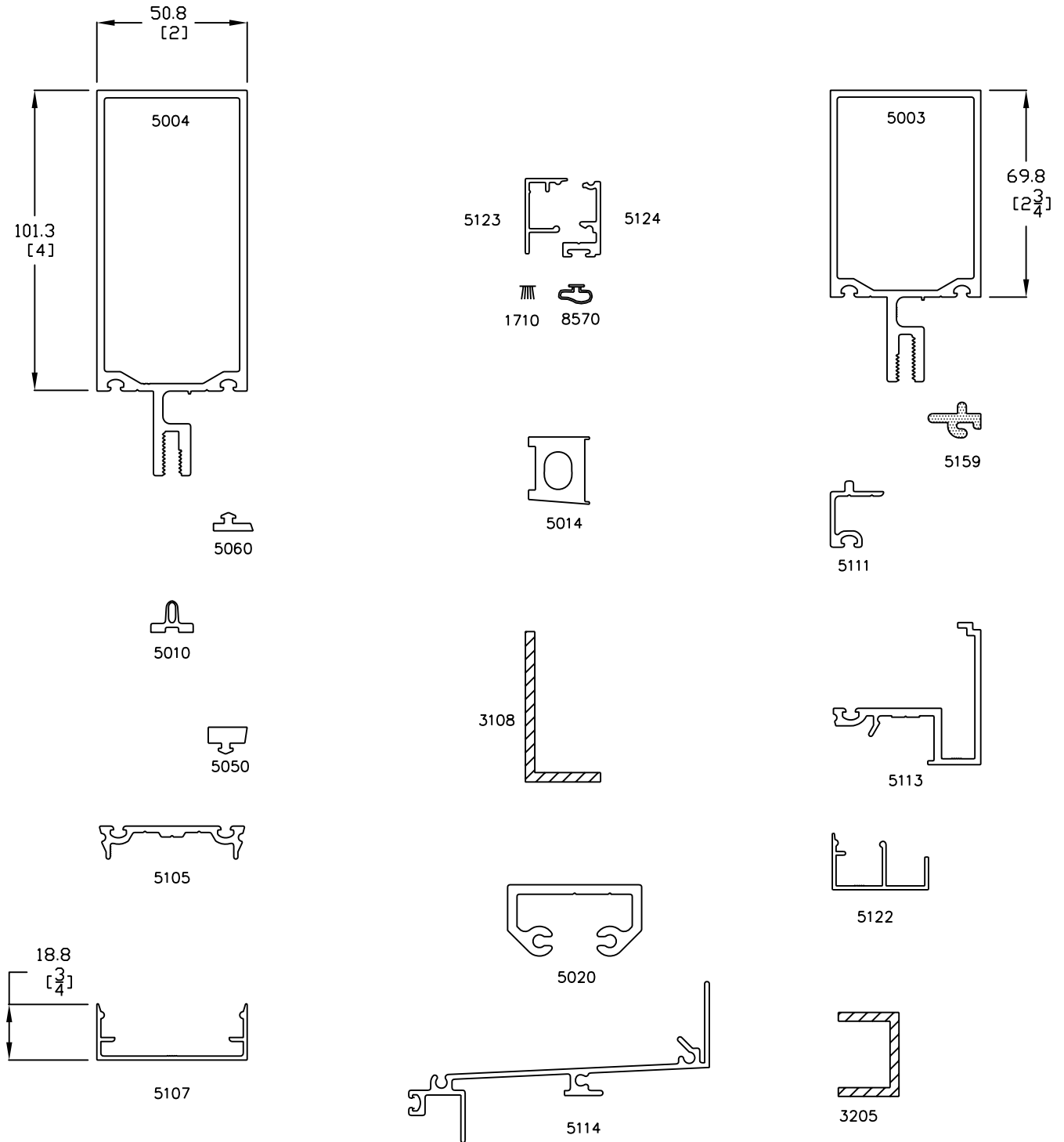

SCALE 1:2

# 5000 SERIES 51mm (2") PRESSURE PLATE FRAMING SYSTEM

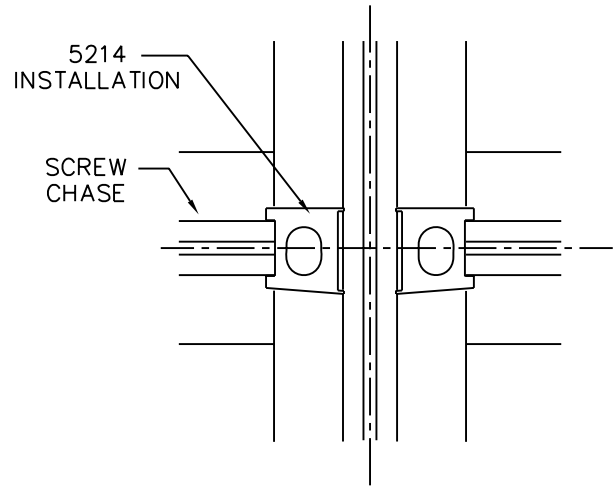
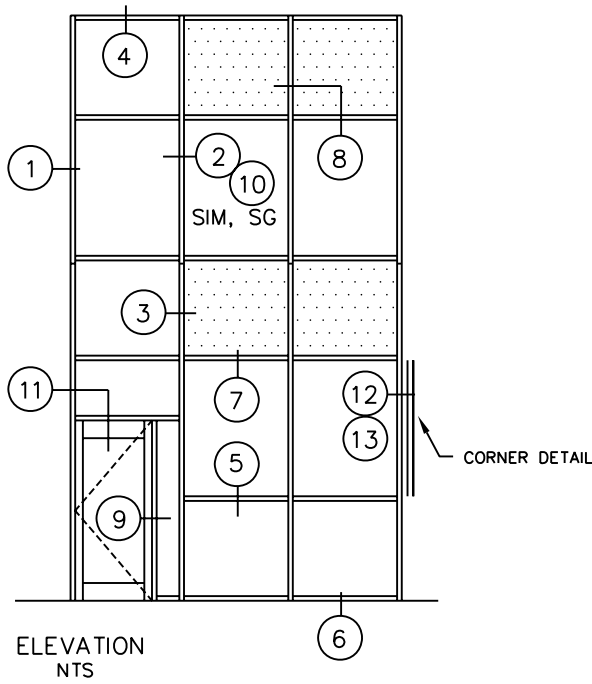

(A) CORNER BLOCK INSTALLATION  
FRONT VIEW

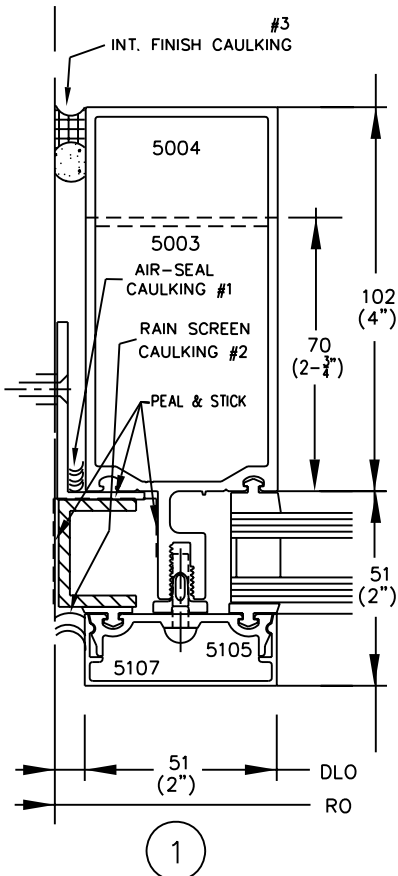

SCALE 1:2

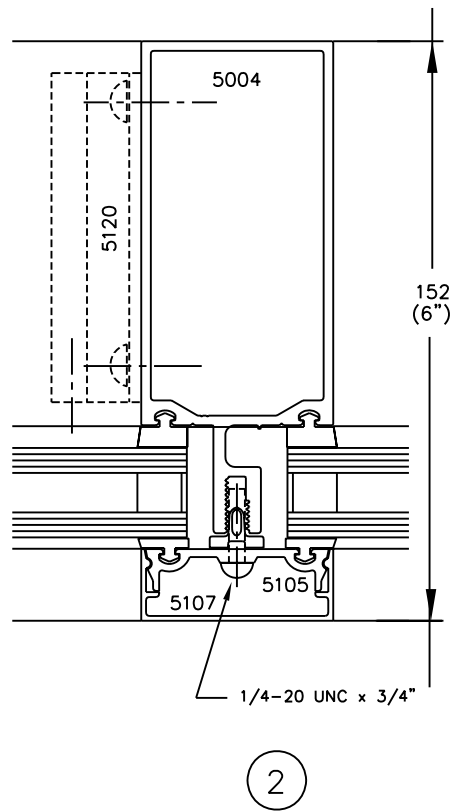

SINGLE  
GLAZING

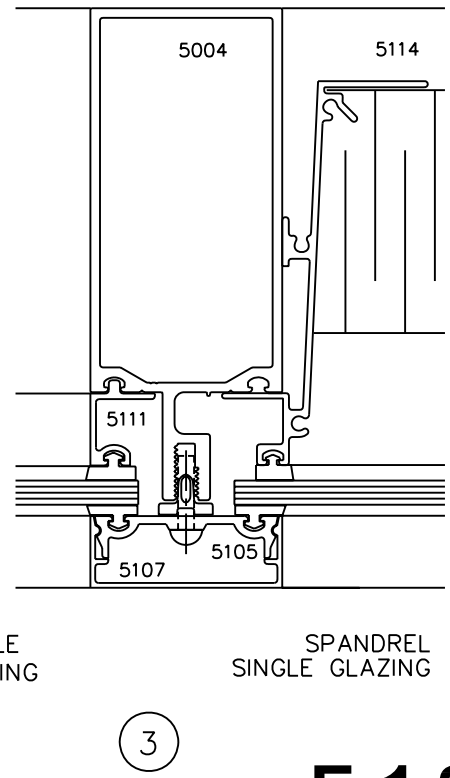

SPANDREL  
SINGLE GLAZING

# 5000 SERIES

## 51mm (2") PRESSURE PLATE FRAMING SYSTEM

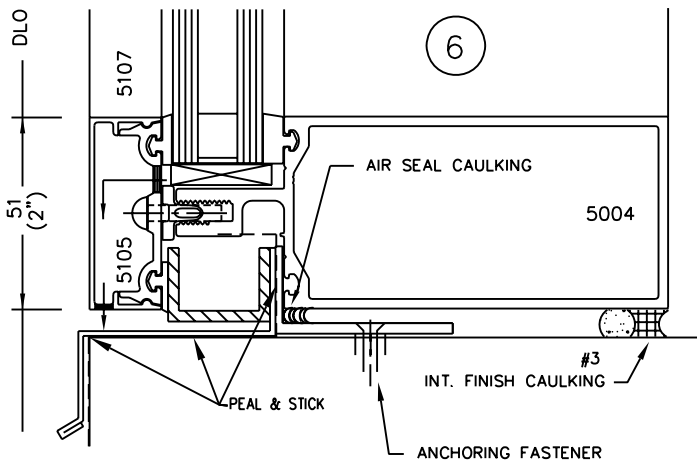
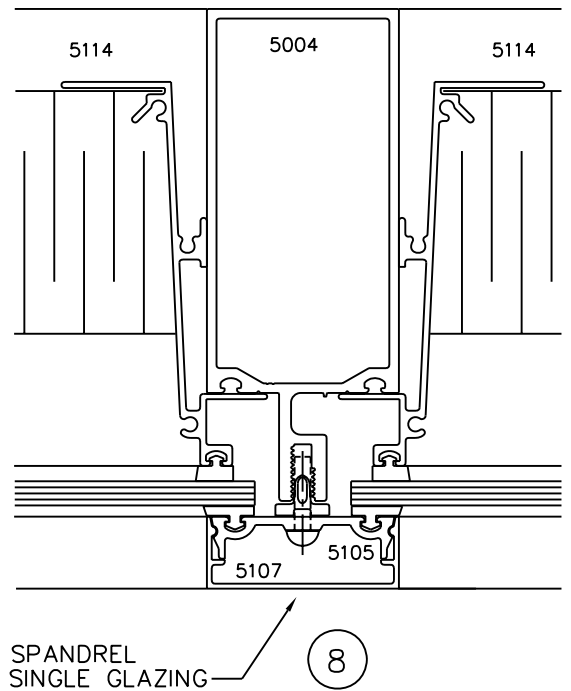
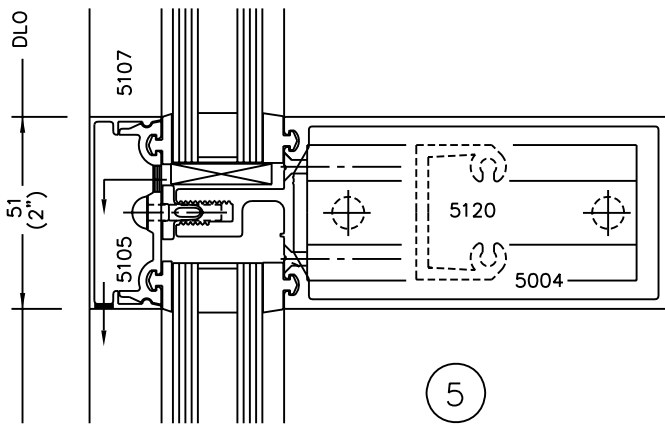
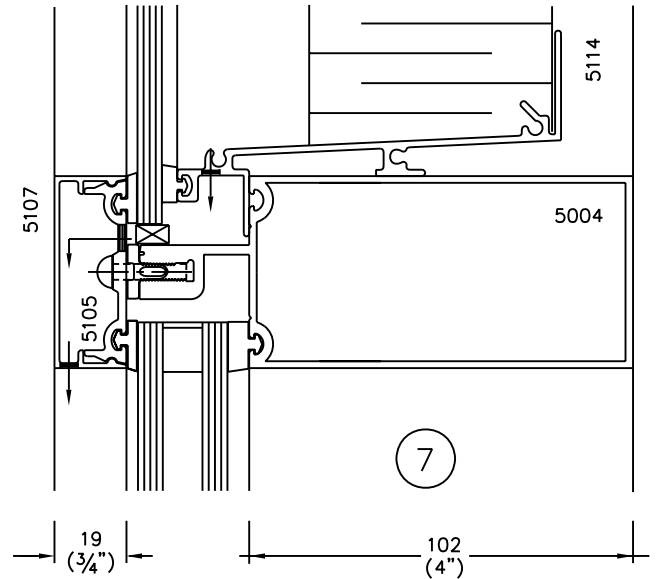
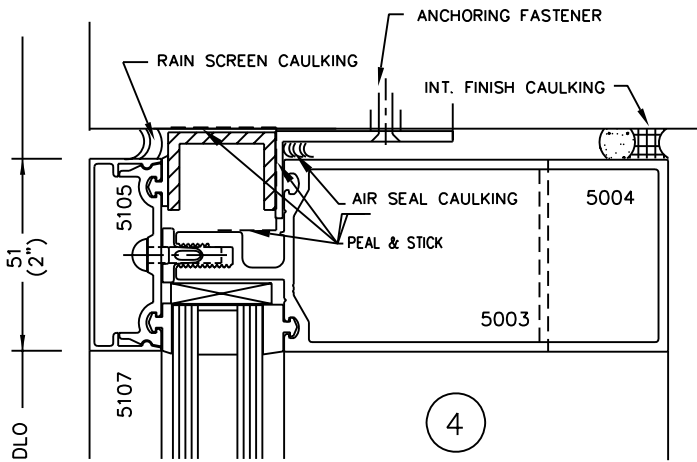

SCALE 1:2

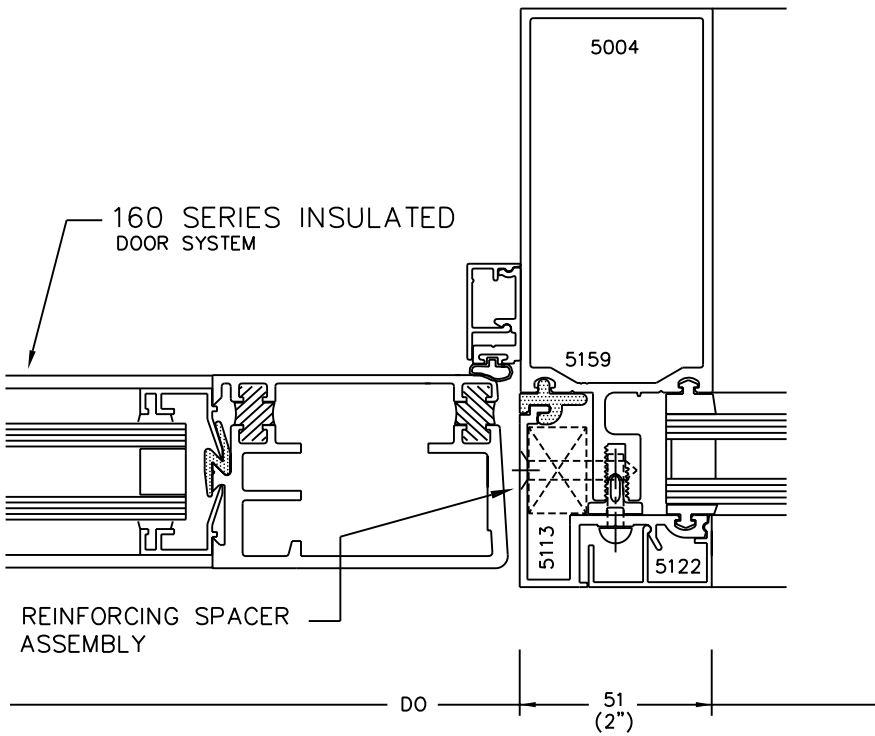

9

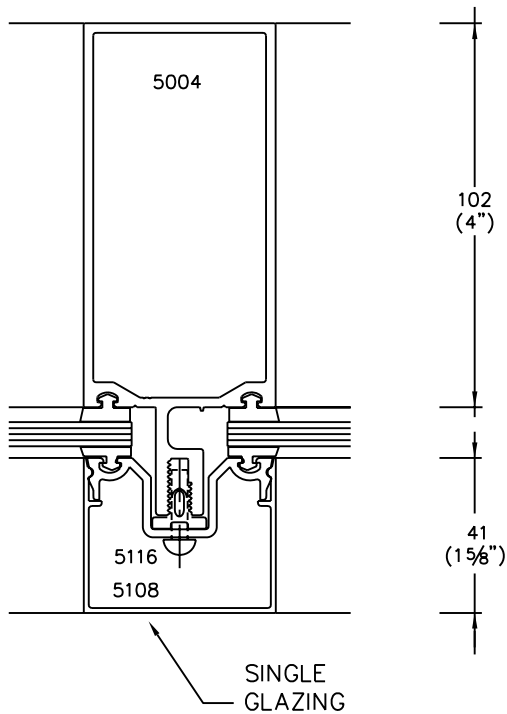

10

SCALE 1:2

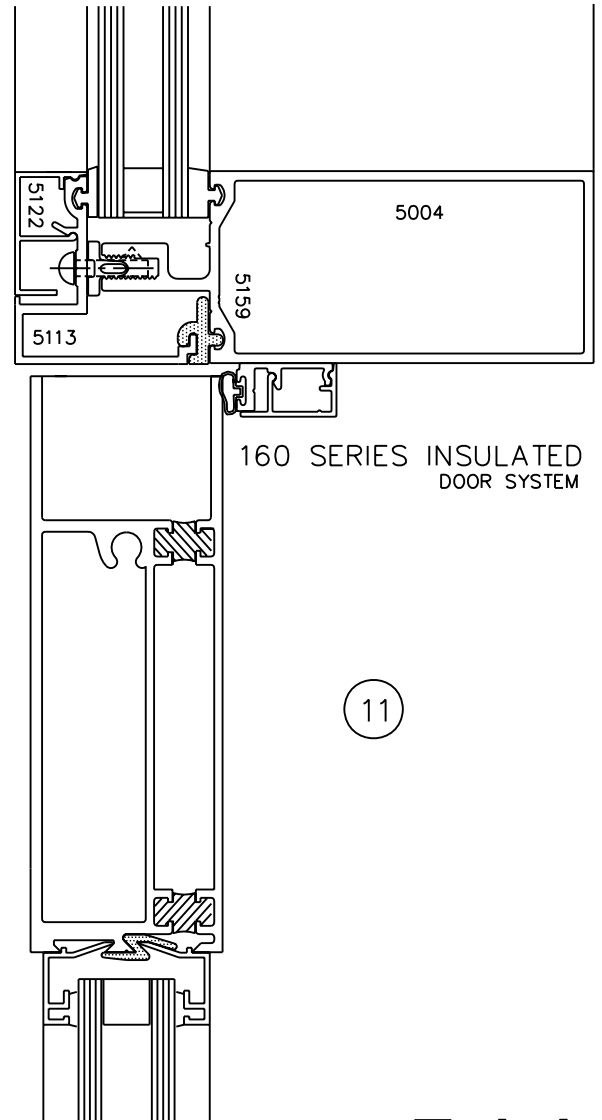

11

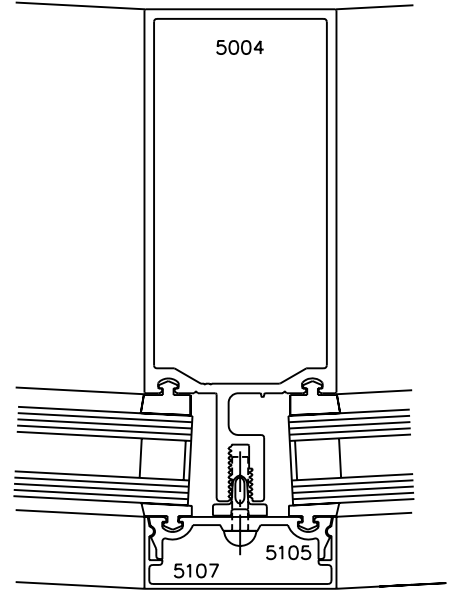
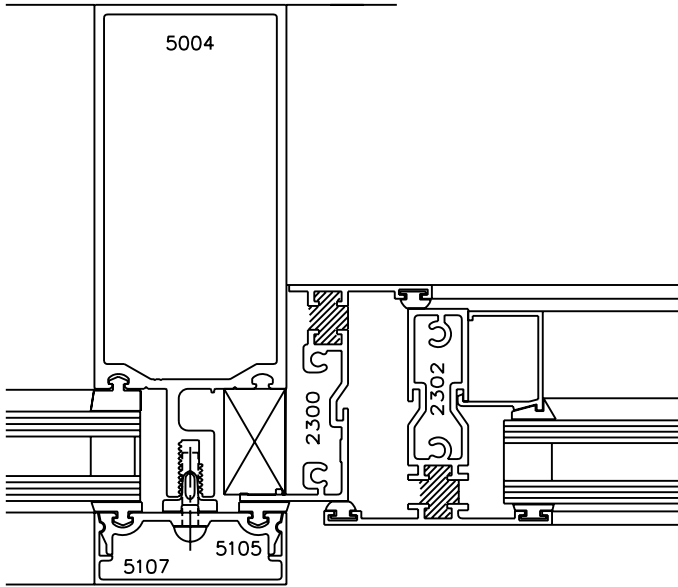

2

Segmented

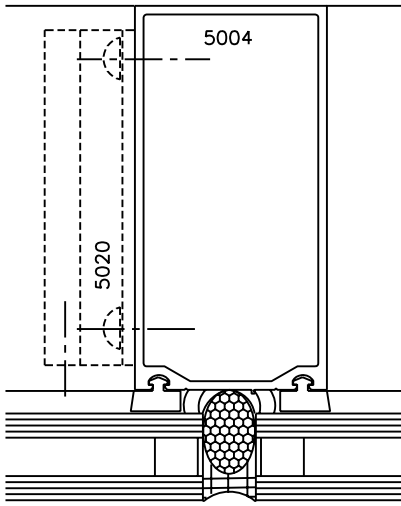

2

SSG Vertical

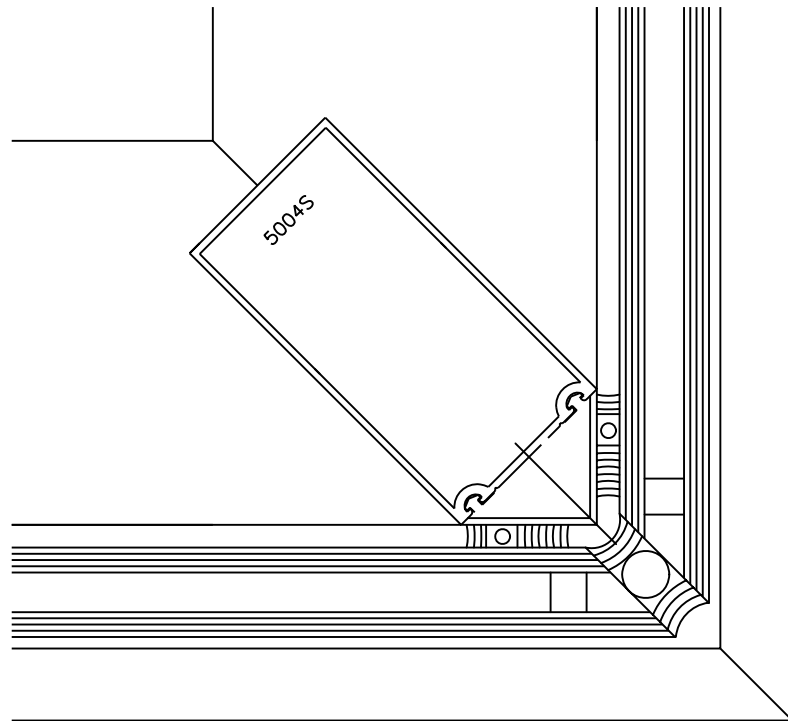

11

SCALE 1:2

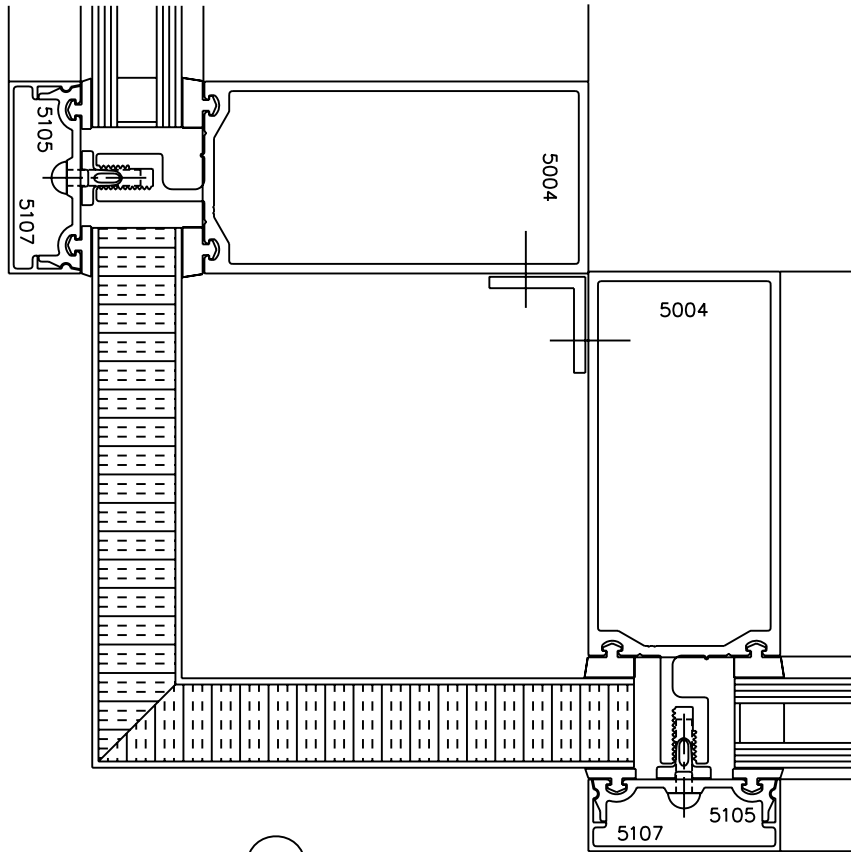

12

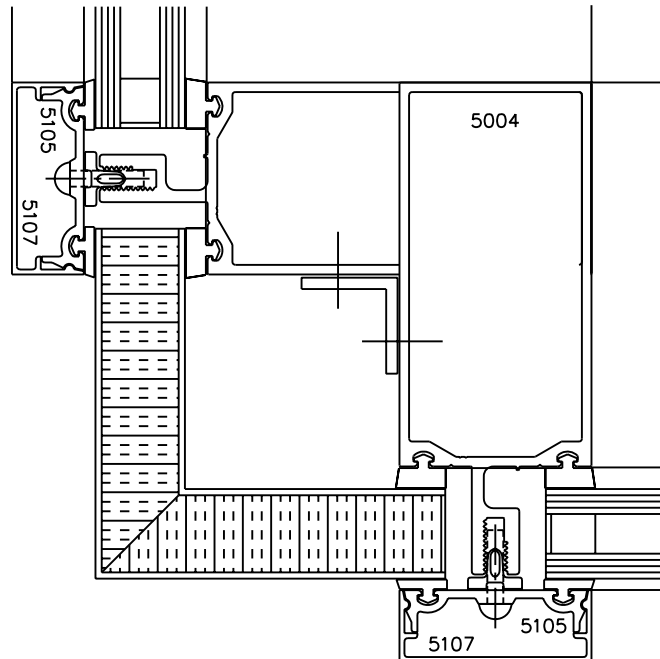

13

CORNER DETAIL

SCALE 1:2

**5000** SERIES  
**51mm (2") PRESSURE PLATE  
 FRAMING SYSTEM**

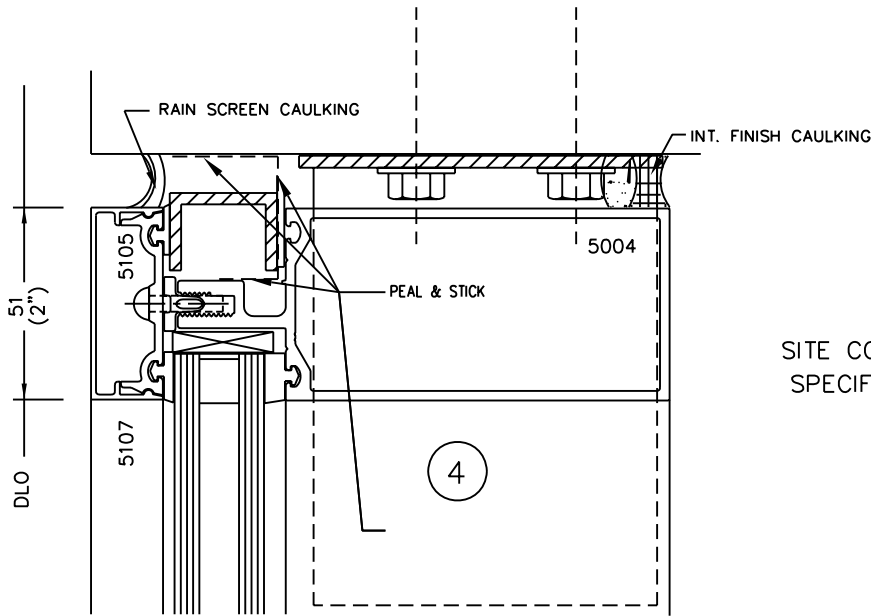

SHOE ANCHOR  
 SITE CONDITION TO DETERMINE  
 SPECIFIC ANCHORS REQUIRED

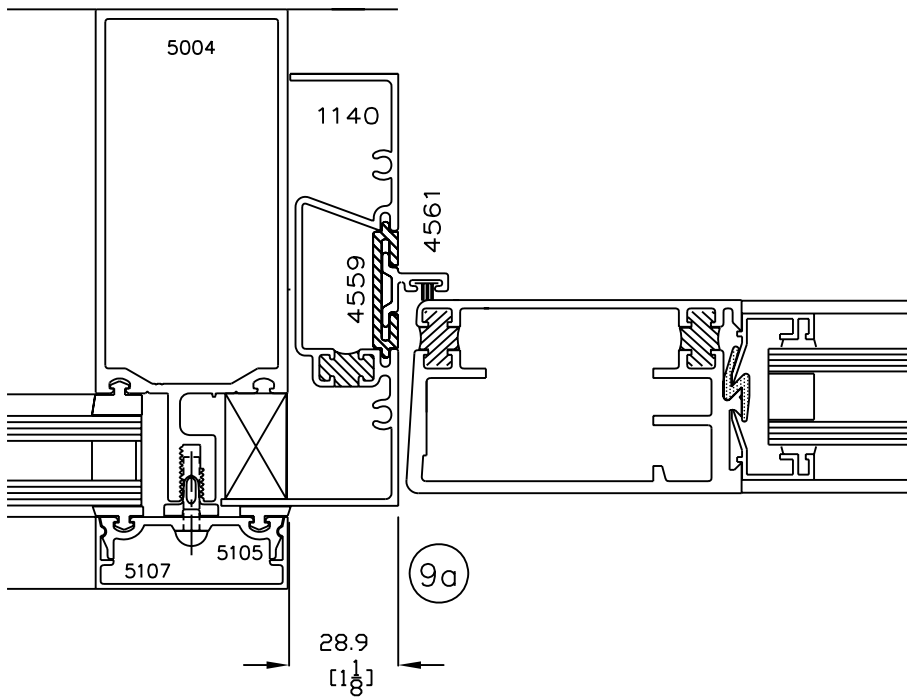

SCALE 1:2



# 5000 SERIES 51mm (2") PRESSURE PLATE FRAMING SYSTEM

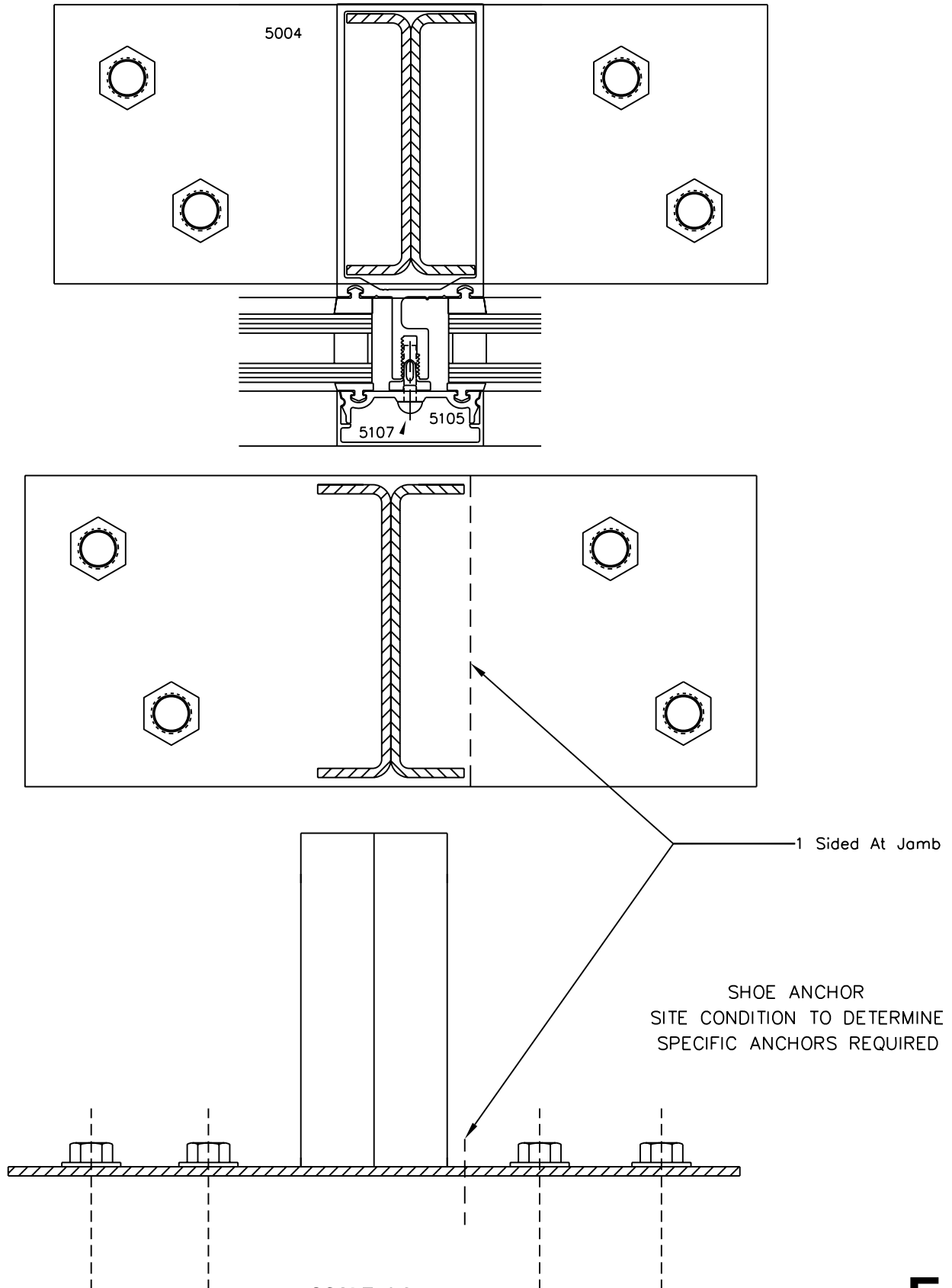

**A.T.MARCK & ASSOCIATES**  
BUILDING SYSTEMS ENGINEERING LTD.  
TEL/FAX (604) 941-3921

PROFILE : 5004 + 5005 WITHOUT HORIZONTALS		AA 6063 T5
I = .245E+07 mm <sup>4</sup>	S = .324E+05 mm <sup>3</sup>	
MAX. ALLOWABLE LENGTH ( m / ft ) FOR SPECIFIED WIND LOAD		

SPACING	0.72 kPa	0.96 kPa	1.20 kPa	1.44 kPa	1.68 kPa	1.91 kPa	m ft
	15 PSF	20 PSF	25 PSF	30 PSF	35 PSF	40 PSF	
.30 m	7.04	6.40	5.94	5.59	5.31	5.09	m ft
1.0'	23.10	21.00	19.50	18.35	17.40	16.70	
.45 m	6.15	5.59	5.19	4.88	4.64	4.44	m ft
1.5'	20.20	18.35	17.05	16.00	15.20	14.55	
.60 m	5.59	5.08	4.71	4.44	4.21	4.04	m ft
2.0'	18.35	16.55	15.45	14.55	13.50	12.65	
.75 m	5.19	4.71	4.36	3.98	3.68	3.46	m ft
2.5'	17.05	15.45	14.27	13.05	12.05	11.35	
.90 m	4.88	4.44	3.98	3.63	3.36	3.15	m ft
3.0'	16.00	14.55	13.05	11.90	11.00	10.35	
1.05 m	4.64	4.12	3.68	3.36	3.11	2.92	m ft
3.5'	15.22	13.51	12.05	11.00	10.20	9.60	
1.20 m	4.44	3.85	3.45	3.15	2.91	2.73	m ft
4.0'	14.55	12.65	11.30	10.35	9.55	8.95	
1.35 m	4.19	3.63	3.24	2.97	2.75	2.58	m ft
4.5'	13.75	11.90	10.65	9.75	9.00	8.45	
1.50 m	3.98	3.45	3.08	2.81	2.61	2.44	m ft
5.0'	13.10	11.30	10.10	9.20	8.55	8.00	
1.65 m	3.79	3.29	2.94	2.68	2.48	2.33	m ft
5.5'	12.45	10.80	9.65	8.80	8.15	7.65	
1.80 m	3.63	3.15	2.81	2.57	2.38	2.23	m ft
6.0'	11.90	10.35	9.20	8.45	7.80	7.30	
1.95 m	3.49	3.02	2.70	2.47	2.28	2.14	m ft
6.5'	11.45	9.90	8.85	8.10	7.50	7.00	
2.10 m	3.36	2.91	2.61	2.38	2.20	2.07	m ft
7.0'	11.00	9.55	8.55	7.80	7.20	6.80	
2.25 m	3.25	2.81	2.52	2.30	2.13	1.99	m ft
7.5'	10.65	9.20	8.25	7.55	7.00	6.55	
2.40 m	3.15	2.72	2.44	2.22	2.06	1.93	m ft
8.0'	10.35	8.90	8.00	7.30	6.75	6.35	

Profile	5004 / 5105			Reinforcing		
				with 1 1/2" x 3 1/2" x 1/8" Steel Channel		
	A ( mm <sup>2</sup> ) = 100			A ( in <sup>2</sup> ) = 0.1550003		
	I ( mm <sup>4</sup> ) = 4222139			I ( in <sup>4</sup> ) = 10.14373		
	LG.CEN ( mm ) = 61.1			LG.CEN ( IN ) = 2.405512		
	S = ( mm <sup>3</sup> ) = 69102			S ( in <sup>3</sup> ) = 4.216863		
Max. Allowable Length (m/ft) for specified Wind Load						
Spacing	0.72kPa 15 PSF	0.96kPa 20PSF	1.20kPa 25PSF	1.44kPa 30PSF	1.68kPa 35PSF	1.91kPa 40PSF
0.30 m	8.45	7.65	7.10	6.70	6.35	6.10
1.0'	27.7	25.1	23.3	22.0	20.8	20.0
0.45 m	7.35	6.70	6.20	5.85	5.55	5.30
1.5'	24.1	22.0	20.3	19.2	18.2	17.4
0.60 m	6.70	6.10	5.65	5.30	5.05	4.85
2.0'	22.0	20.0	18.5	17.4	16.6	15.9
0.75 m	6.20	5.65	5.25	4.95	4.70	4.50
2.5'	20.3	18.5	17.2	16.2	15.4	14.8
0.90 m	5.85	5.30	4.95	4.65	4.40	4.20
3.0'	19.2	17.4	16.2	15.3	14.4	13.8
1.05 m	5.55	5.05	4.70	4.40	4.20	4.00
3.5'	18.2	16.6	15.4	14.4	13.8	13.1
1.20 m	5.30	4.85	4.50	4.20	4.00	3.85
4.0'	17.4	15.9	14.8	13.8	13.1	12.6
1.35 m	5.10	4.65	4.30	4.05	3.85	3.70
4.5'	16.7	15.3	14.1	13.3	12.6	12.1
1.50 m	4.95	4.50	4.15	3.90	3.70	3.55
5.0'	16.2	14.8	13.6	12.8	12.1	11.6
1.65 m	4.80	4.35	4.05	3.80	3.60	3.40
5.5'	15.7	14.3	13.3	12.5	11.8	11.2
1.80 m	4.65	4.20	3.90	3.70	3.45	3.25
6.0'	15.3	13.8	12.8	12.1	11.3	10.7
1.95 m	4.50	4.10	3.80	3.60	3.35	3.10
6.5'	14.8	13.5	12.5	11.8	11.0	10.2
2.10 m	4.40	4.00	3.70	3.45	3.20	3.00
7.0'	14.4	13.1	12.1	11.3	10.5	9.8
2.25 m	4.30	3.90	3.65	3.35	3.10	2.90
7.5'	14.1	12.8	12.0	11.0	10.2	9.5
2.40 m	4.20	3.85	3.55	3.25	3.00	2.80
8.0'	13.8	12.6	11.6	10.7	9.8	9.2